



Feature

- Full diffusion process
- Capsule type ceramic package
- Double side cooling

- High power transmission
- Welding equipment
- Motor control and drive
- Battery charger

$I_{F(AV)}$	2500A
V_{RRM}	100-5000V
I_{FSM}	40 KA
I^2t	8000 $10^3 a^2s$

SYMBOL	CHARACTERISTIC	TEST CONDITIONS	T_J (°C)	VALUE		UNIT
				Min	Max	
$I_{F(AV)}$	Mean forward current	180° half sine wave 50Hz Double side cooled, THS=97°C	150		2500	A
V_{RRM}	Repetitive peak reverse voltage	$V_{DRM} \& V_{RRM} t_p=10ms$ $V_{DSM} \& V_{RSM}=V_{DRM} \& V_{RRM}+100V$	150	100	5000	V
I_{RRM}	Repetitive peak current	$V_{RM}=V_{RRM}$	150		160	mA
I_{TSM}	Surge on-state current	10ms half sine wave	150		40	KA
I^2t	I^2t for fusing coordination	$V_R=0.6V_{RRM}$			8000	$A^{2S*}1$
V_{FO}	Threshold voltage		150		0.86	V
r_T	On-state slop resistance				0.11	$m\Omega$
V_{FM}	Peak on-state voltage	$I_{TM}=5000A, F=15KN$	25		2.0	V
I_{RM}	Reverse recovery current	$I_{TM}=5000A, t_q=1000us$ $Di/dt=-20A/us.$ $V_f=50V$	150		168	A
t_{rr}	Reverse recovery time				6.8	us
Q_{rr}	Recovery charge				571	uC
$R_{th(j-h)}$	Thermal resistance Junction to heat sink	At180° sine double side cooled Clamping force 5.0kn			0.011	°C/W
F_M	Mounting force			35	47	KN
T_{stq}	Stored temperature			-40	190	°C
W_t	Weight					g
Outline						

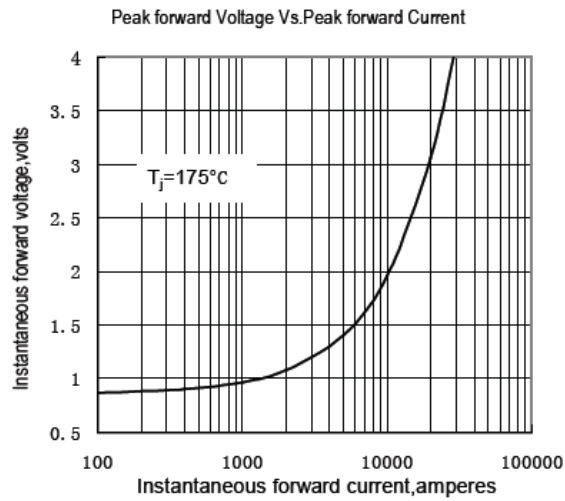

Fig.1

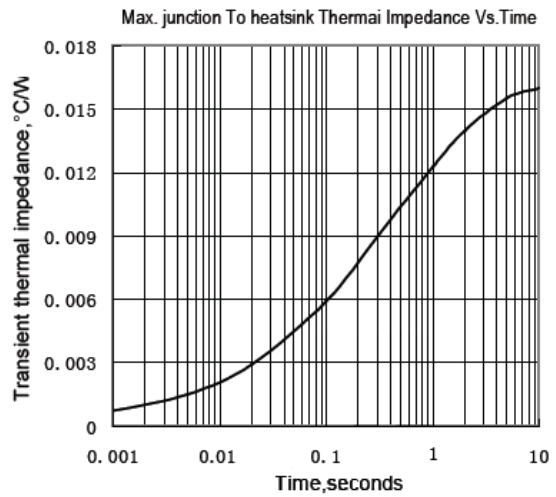

Fig.2

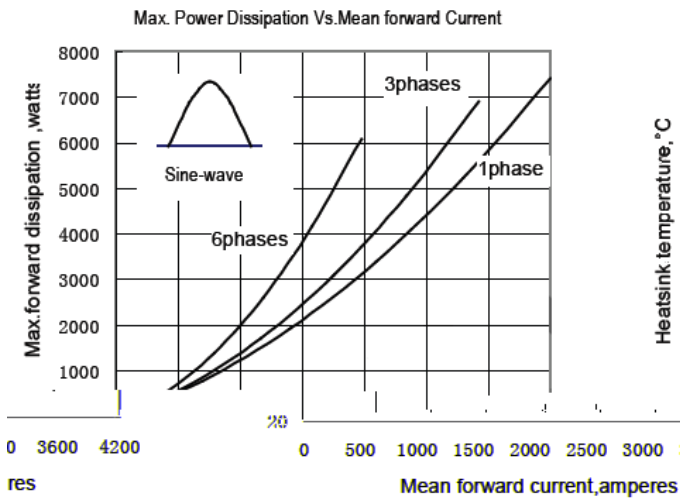

Fig.4

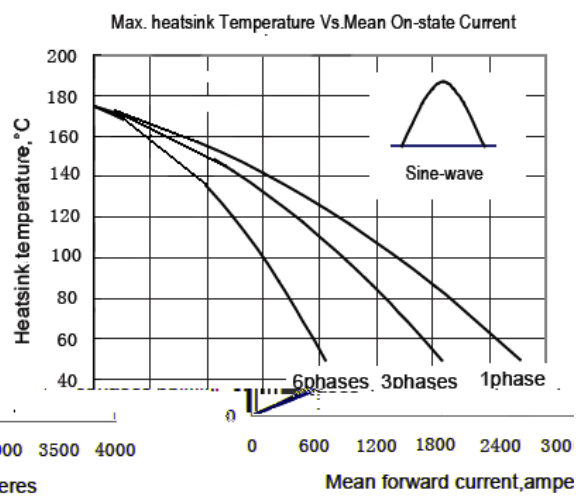

Fig.3

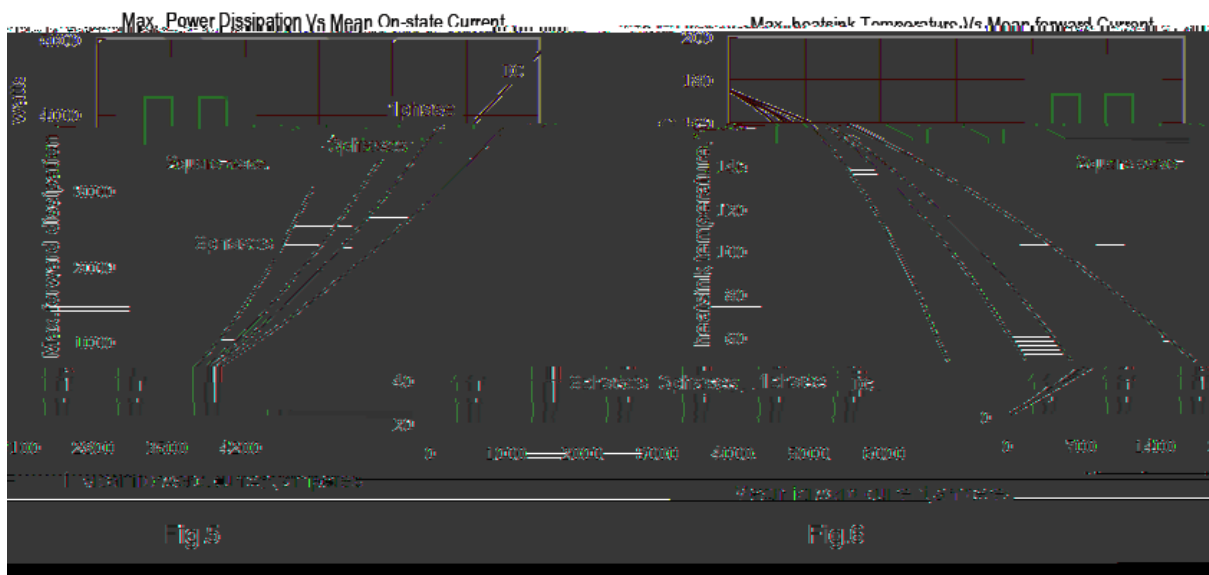

Fig.5

Fig.6

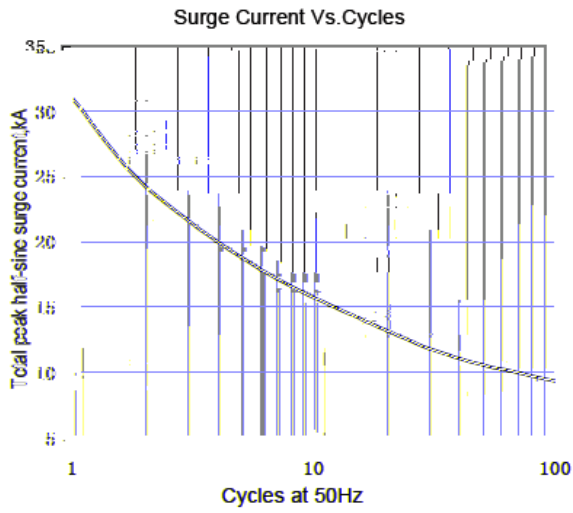

Fig.7

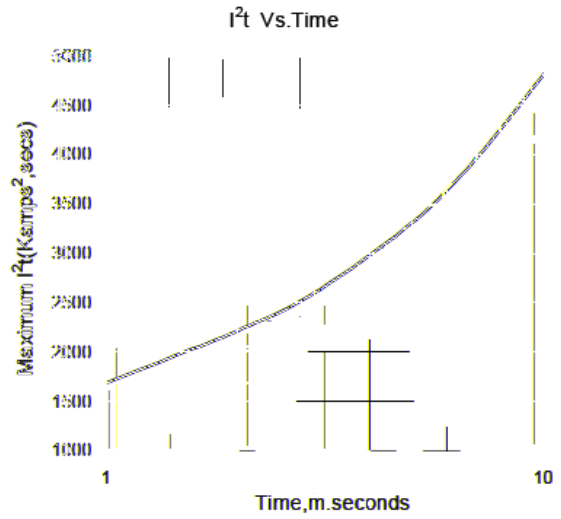
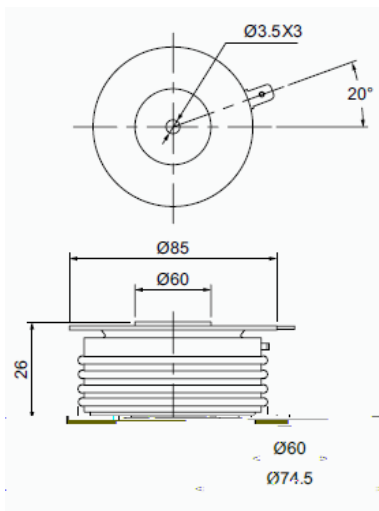
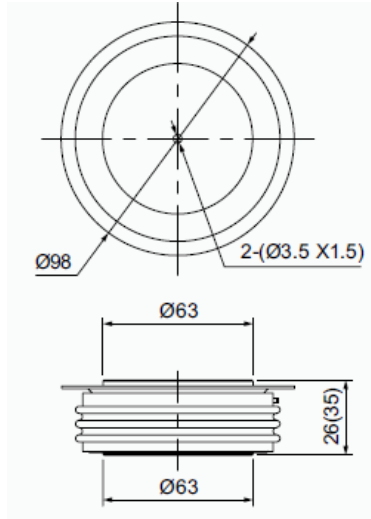

Fig.8

Outline:



1



2

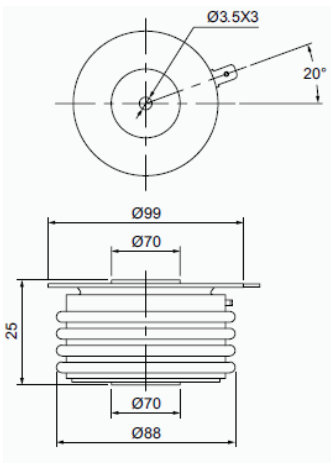

3

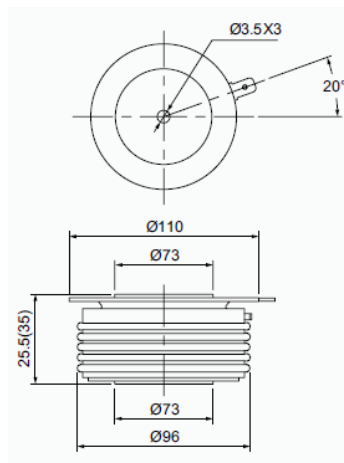

4